

# CLY 760 3-710: 3x710KG CABLE DRUM TRAILER Data Sheet

**Clydesdale Ltd.**  
Instal House, 3 Sunbeam Rd  
Woburn Road Ind. Est., Kempston  
Bedfordshire MK42 7BZ  
United Kingdom

T: +44 (0) 1234 855 855  
F: +44 (0) 1234 855 800  
E: sales@clydesdale.ltd.uk  
www.clydesdale.ltd.uk

The innovative Clydesdale 3-Drum trailer can be used to carry a combination of 1, 2 or 3 drums.

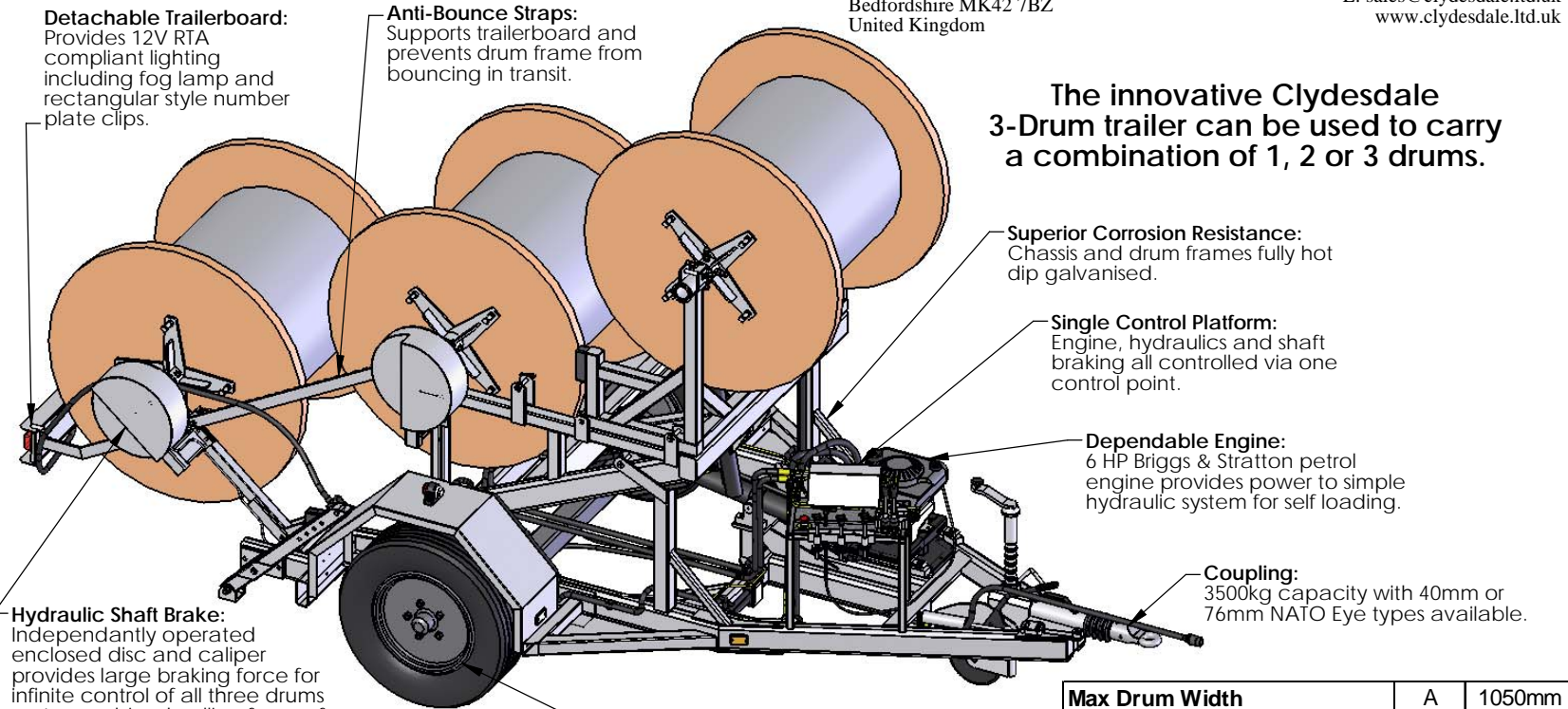
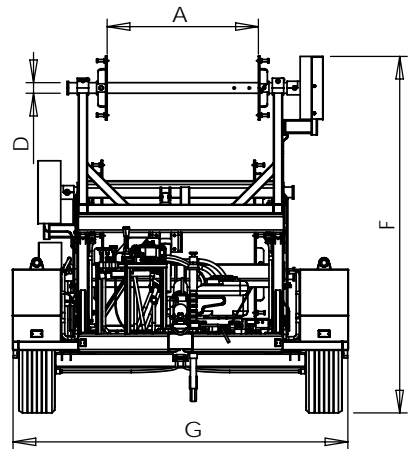
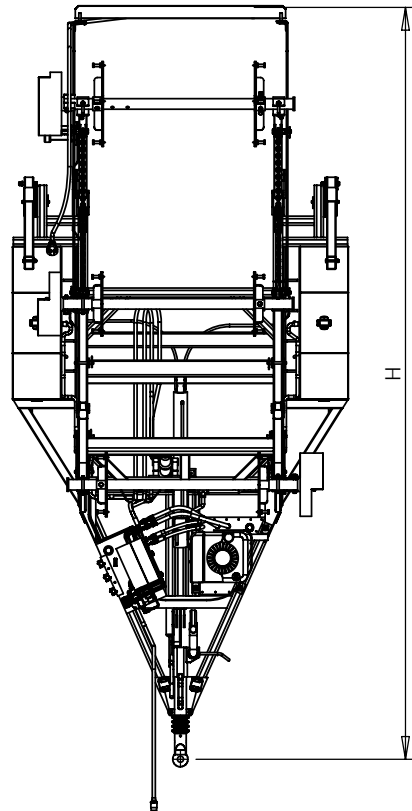

**Detachable Trailerboard:**  
Provides 12V RTA compliant lighting including fog lamp and rectangular style number plate clips.

**Anti-Bounce Straps:**  
Supports trailerboard and prevents drum frame from bouncing in transit.

**Superior Corrosion Resistance:**  
Chassis and drum frames fully hot dip galvanised.

**Single Control Platform:**  
Engine, hydraulics and shaft braking all controlled via one control point.

**Dependable Engine:**  
6 HP Briggs & Stratton petrol engine provides power to simple hydraulic system for self loading.

**Hydraulic Shaft Brake:**  
Independently operated enclosed disc and caliper provides large braking force for infinite control of all three drums up to combined pulling force of 2000kg.

**Suspension:**  
Maximum width 12 PR tyres for 17.5" rim with 250mm section width on full beam rubber axle with auto-reverse overrun type braking.

**Coupling:**  
3500kg capacity with 40mm or 76mm NATO Eye types available.

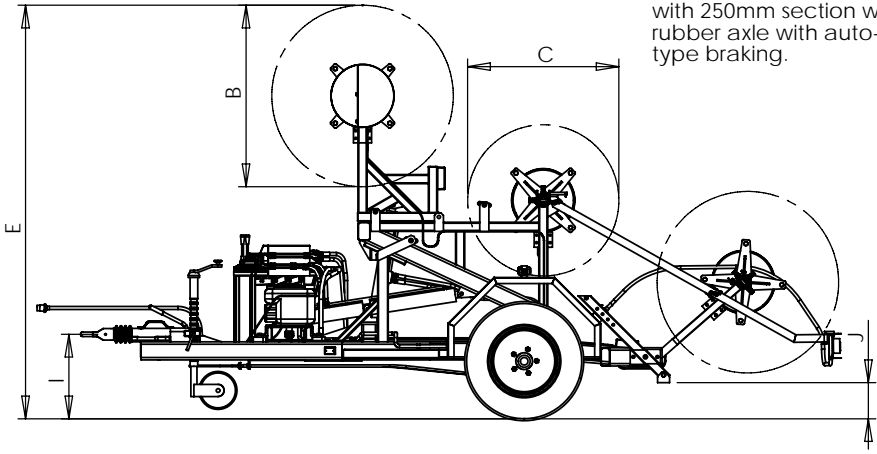

<b>Max Drum Width</b>	A	1050mm
<b>Max Drum Diameter</b>	B	1200mm
<b>Min Drum Diameter</b>	C	1000mm
<b>Min Spindle Hole Diameter</b>	D	70mm
<b>Max Loaded Trailer Height</b>	E	2740mm
<b>Max Unloaded Trailer Height</b>	F	2365mm
<b>Trailer Width</b>	G	2220mm
<b>Trailer Length (Complete)</b>	H	5190mm
<b>Coupling height (Level)</b>	I	559mm
<b>Road Clearance (Level)</b>	J	175mm
<b>Number of Drums</b>		1,2 or 3
<b>Max Drum Weight (Per Drum)</b>		710kg
<b>Max Combined Drum Weight</b>		2130kg
<b>Unladen Trailer Weight</b>		1110kg
<b>Max Laden Trailer Weight</b>		3240kg
<b>Max Braking Torque (Per Drum)</b>		500Nm