

CLY 760 3-400: 3X400KG THREE DRUM TRAILER Data Sheet

The innovative Clydesdale three drum trailer can be used to carry a combination of 1, 2 or 3 drums.

CLYDESDALE

Powering the Future

Clydesdale Ltd.
Instal House, 3 Sunbeam Rd
Woburn Road Ind. Est., Kempston
Bedfordshire MK42 7BZ
United Kingdom

T: +44 (0) 1234 855 855
F: +44 (0) 1234 855 800
E: sales@clydesdale.ltd.uk
www.clydesdale.ltd.uk

Detachable Trailerboard:
Provides 12V RTA compliant lighting including fog lamp and rectangular style number plate clips.

Bottom Frame Trusses:
Supports trailerboard and prevents bottom drum frame from bouncing in transit.

Sturdy Hand Winch:
With load load pressure brake for loading/unloading top drum frame with ease.

Dependable Engine:
Provides power to simple hydraulic system for self loading.

This trailer is available with wider off-road tyres and mudguards for improved accessibility in wet conditions.

Superior Corrosion Resistance:
Chassis and drum frames galvanised.

Various Coupling Head Types:
30mm Eye, 40mm Eye, 76m Nato Eye and 50mm Ball Head options available.

Hydraulic Shaft Brake:
Independently operated enclosed disc and caliper provide large braking force for infinite control of all three drums.

Deflector Wings:
Prevent mudguard damage from fence post and other obstacles.

Single Control Platform:
Engine, hydraulics and shaft braking all controlled via one control point.

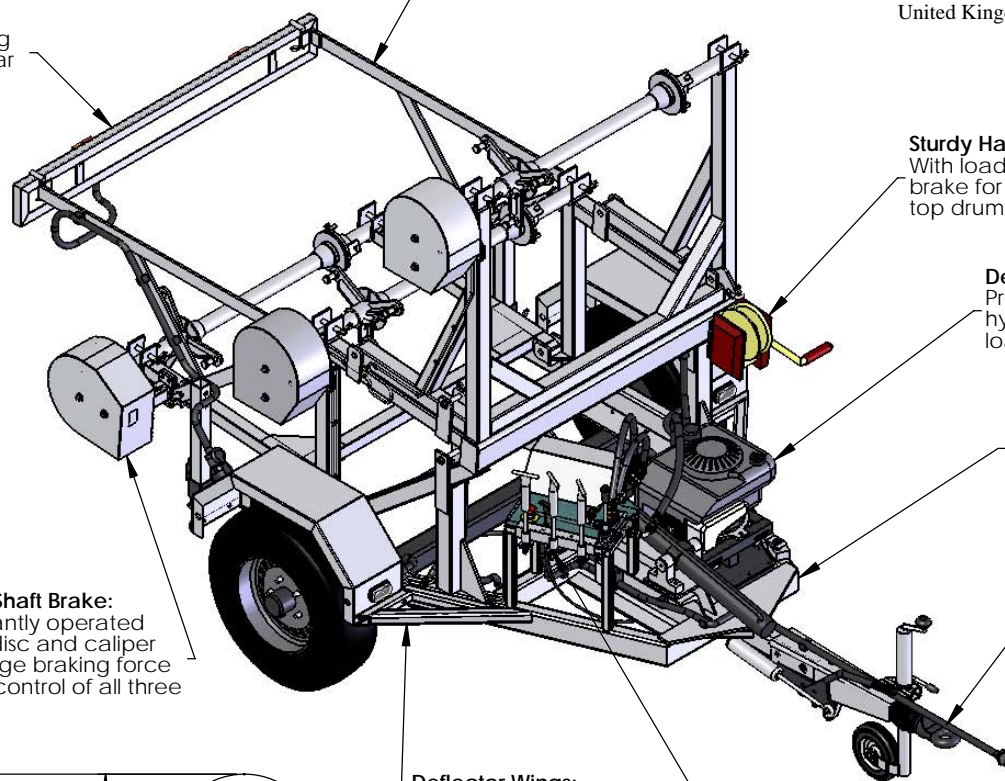
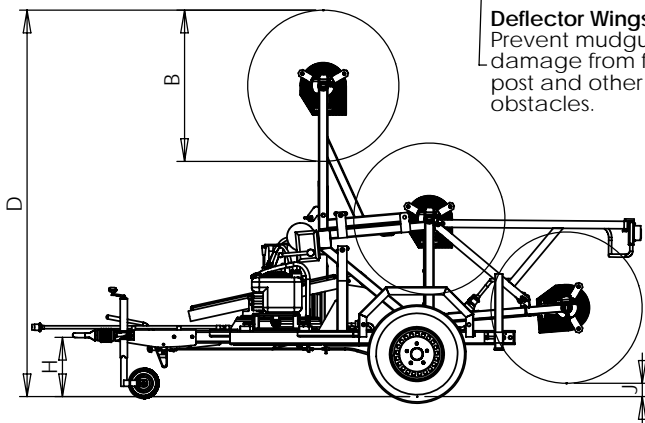
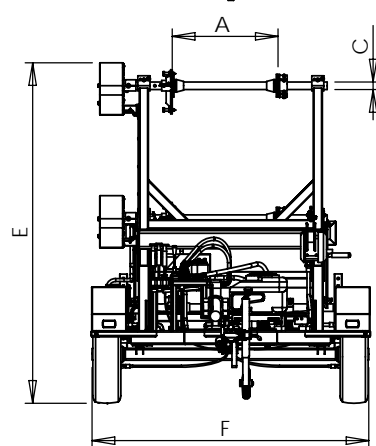
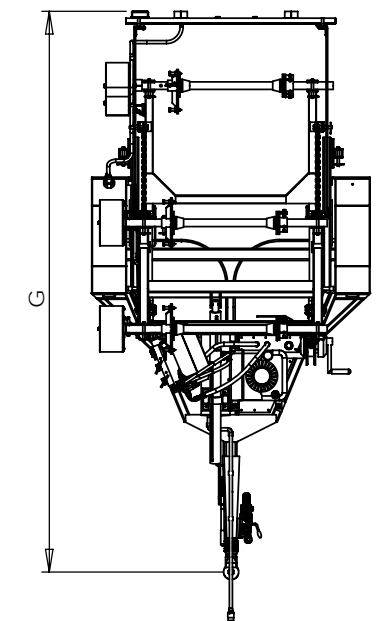

Max Drum Width	A	900mm
Max Drum Diameter	B	1000mm
Min Drum Hole Diameter	C	50mm
Max Loaded Trailer Height	D	2555mm
Max Unloaded Trailer Height	E	2250mm
Trailer Width	F	1840mm
Trailer Length	G	3700mm
Coupling Height (when level)	H	440mm
Road Clearance (when level)	J	190mm
Max Drum Weight		400kg
Unladen Weight		600kg
Max Laden Weight		1800kg
Min Drum Diameter		700mm