

CLY 640 3000: FLATBED RAILWAY DRUM CRADLE Data Sheet

CLYDESDALE

Powering the Future

Clydesdale Ltd.
Instal House, 3 Sunbeam Rd
Woburn Road Ind. Est., Kempston
Bedfordshire MK42 7BZ
United Kingdom

T: +44 (0) 1234 855 855
F: +44 (0) 1234 855 800
E: sales@clydesdale.ltd.uk
www.clydesdale.ltd.uk

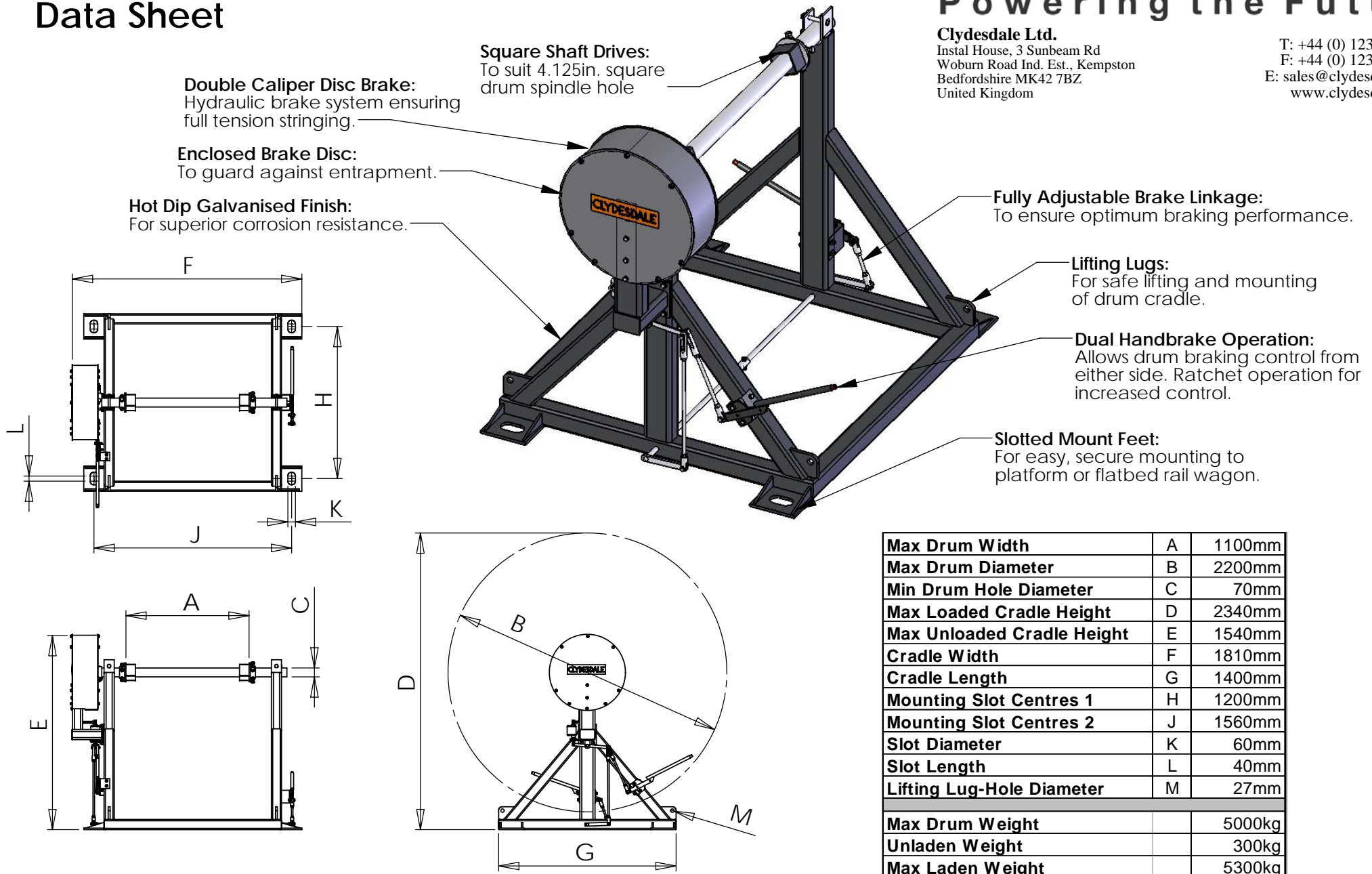

Max Drum Width	A	1100mm
Max Drum Diameter	B	2200mm
Min Drum Hole Diameter	C	70mm
Max Loaded Cradle Height	D	2340mm
Max Unloaded Cradle Height	E	1540mm
Cradle Width	F	1810mm
Cradle Length	G	1400mm
Mounting Slot Centres 1	H	1200mm
Mounting Slot Centres 2	J	1560mm
Slot Diameter	K	60mm
Slot Length	L	40mm
Lifting Lug-Hole Diameter	M	27mm
<hr/>		
Max Drum Weight		5000kg
Unladen Weight		300kg
Max Laden Weight		5300kg